

Franke Coffee Systems
Evolution Plus:
even more choice at the touch of a button.



FRANKE

COFFEE
SYSTEMS

The art of excellent coffee-making

Evolution Plus:

Trendy coffee creations to suit every taste.



The Evolution Plus lets you broaden your choice of coffee specialities in an instant, fulfilling virtually every customer wish. The Evolution Plus exceeds every expectation with its power-packed performance, stylish and ergonomic Pre-Selection Plus operating unit fashioned from glass and a compact width of only 32 cm. It lets you program up to 32 different beverages, with coffee and/or milk, at four different levels, displaying them on the large graphic display. With up to 16 programmable pre-select buttons you can now expand the range of beverages with a multitude of pre-select options, including the beverage size and the type of milk or coffee bean. The KE320 refrigeration unit has the capacity to store 10 litres of milk and, aesthetically, it perfectly matches the coffee machine. So, whether in fashionable restaurants and bars, hotels or the self-service sector, the Evolution Plus is the ideal coffee machine when it comes to:

The art of excellent coffeemaking



Evolution Plus: version with milk system.

The CF milk system

Drinking habits change, and that's also true of coffee; indeed coffee specialities are now the "in"-thing. Today virtually every successful restaurateur operates a coffee machine with milk system. And in keeping with the trend towards higher milk consumption, Franke has developed a refrigeration unit capable of storing up to 10 litres of milk.

With the integrated milk system in the KE320 refrigeration unit a pump delivers the milk to the frother head. Cold and/or hot fresh milk and frothed milk are dispensed as a result. One particular advantage of the milk system is that it serves up constant amounts when demand is high and at peak times. A second type of milk, e.g. low-fat milk, can also be processed as an option.

Another advantage of the milk system is its ability to supply two coffee machines with fresh milk. In this case the refrigerator is placed in the middle between two coffee machines. Franke also supplies a space-saving version, with the refrigeration unit installed under the counter.

All Franke milk systems are HACCP-compliant and/or NSF-certified. This means they satisfy the most stringent hygiene regulations.



- Standard KE320 refrigeration unit on the Evolution Plus
- Available for CF milk systems only
- Electronically controlled ambient temperature
- 10-litre milk container or as an option two 5-litre milk containers for a second type of milk
- Available as a counter-top or under-counter version

Hygiene and cleaning

The certified ARCS program (short for Automatic Rinse, Cleaning & Sanitizing System) for the coffee and milk elements with likewise certified cleaning products makes it considerably easier for you to service and care for your Evolution Plus. It guarantees that the milk is processed perfectly every time. The entire fresh-milk system is rinsed automatically at regular, programmable intervals by the patented rinsing process.



Evolution Plus: version with Autosteam Pro.

Autosteam Pro

With the new Autosteam Pro development, you can heat or froth milk at the touch of a button, whenever you need it. Milk, air and steam are automatically blended into perfectly frothed milk. Both the temperature and the air supply can be programmed individually for each product. And with the innovative Peek material there is no longer any risk of the milk sticking, which is an important hygiene aspect. In fact, with the Autosteam Pro, daily cleaning has never been easier.

- Individually programmable temperature settings and air supply
- Minimum heat transfer to the steam pipe, so no risk of burning
- Use of high-quality materials to prevent the heated milk from sticking
- Easy to dismantle for daily cleaning (two components)



Pre-Selection Plus operating unit: pre-selection and beverage selection presented with great style!

The Pre-Selection Plus operating unit fashioned from glass not only stands out by virtue of its ultramodern design; it is also the key to 32 individually programmable beverage creations made from coffee and/or milk. The Pre-Selection Plus operating unit is divided into two areas. The right-hand area comprises up to 16 programmable pre-select buttons. They are used to program different cup sizes (2 dl, 3 dl) and a second, low-fat type of milk, and to pre-select the type of coffee bean. All the programmed pre-select buttons are illuminated. The product buttons, which ultimately dispense your coffee speciality as pre-selected, are arranged around the graphic display in the left-hand area. As a result, operation is simple, ergonomic and clearly laid out, making the Evolution Plus the ideal solution for the self-service sector, too.

- The Pre-Selection panel combines design, electronics and sensor technology with glass as the casing material
- Functional operating panel with up to 16 programmable pre-select buttons
- Possibility of customised labelling of the pre-select buttons using slide-in foils
- Illuminated pre-select buttons, with split-level colour coding to visually identify different groups of options or functions
- 8 product buttons for coffee/milk products and/or coffee/milk mixed drinks
- Buttons that are not programmed are not illuminated; the display also shows selected options and products

Product dispensing procedure

Step 1 – Pre-selection

First pre-select the product you want, e.g.:

- Cup size: medium (2 dl)
- Low-fat milk
- Decaf coffee-bean type

The chosen pre-selection buttons start to blink. It means that, as the person operating the coffee machine, you have a complete overview of the pre-selection you have just made.

Step 2 – Product selection

- Cappuccino

By pressing the product button, e.g. “Cappuccino”, you trigger the preparation of the hot drink, incl. the pre-selection.

Step 1
Pre-selection

Step 2
Product selection

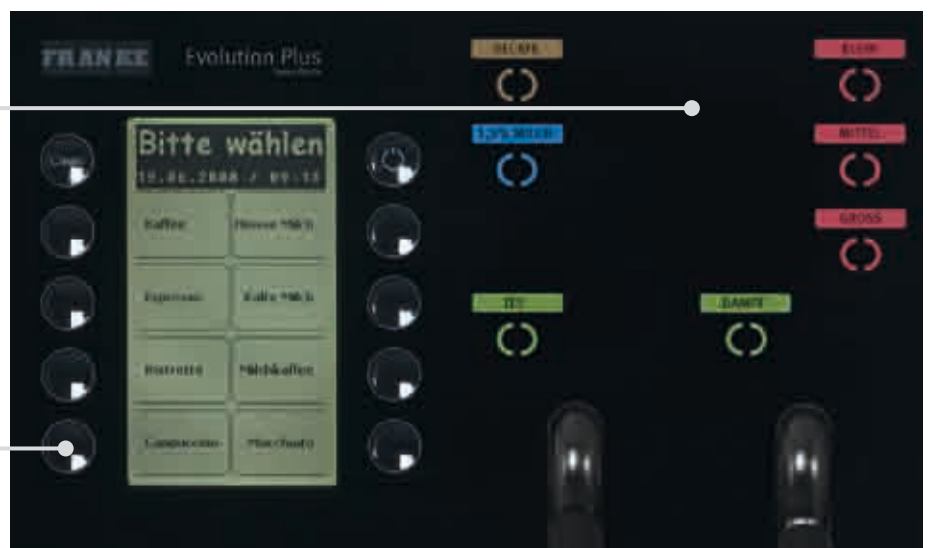

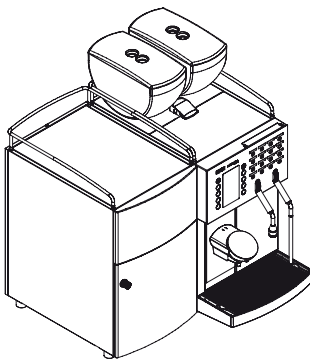
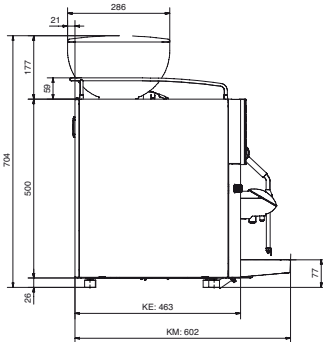
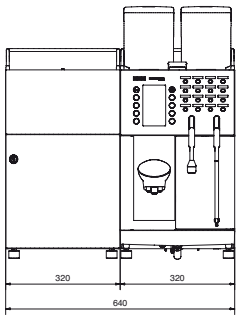

Evolution Plus: Facts & Figures.

Standards

- Fully electronic control board with illuminated graphic display; programming by chip-card or via USB
- 8 product buttons for coffee/milk products
- Up to 32 different beverages with coffee and/or milk individually programmable at four display levels
- Functional Pre-Selection Plus operating panel with up to 16 pre-select buttons, e.g. for beverage sizes, second type of milk, decaf coffee beans, etc.
- Automatic rinsing, cleaning and sanitizing program (ARCS)
- Customised product labelling
- High-performance piston coffee machine with pre-brewing and constant piston heater
- Low-noise precision grinder with direct grinding
- 2 high-grade steel tanks for coffee, hot water & steam
- Height-adjustable coffee/milk dispenser
- Funnel for filling ground coffee manually
- Dry coffee grounds ejected into tray holding 50 portions, with electronic overflow safeguard
- Plastic coffee bean container, capacity 1.3 kg, removable
- Coffee bean level monitoring
- Internal counter functions for each product
- Prepared for connection to standard commercial dispensing and billing systems
- Stainless steel and plastic casing in black or silver

Model	Types	Output in kW	Electrical connection*
Evolution Plus	A II 1M H	5.2	400 V, 2LN, PE, 50/60 Hz, 16 A
Evolution Plus	A II 1M HD	5.2	400 V, 2LN, PE, 50/60 Hz, 16 A
Evolution Plus	A II 1M H CF	5.2	400 V, 2LN, PE, 50/60 Hz, 16 A
Evolution Plus	A II 1M HD CF	5.2	400 V, 2LN, PE, 50/60 Hz, 16 A
Evolution Plus	A II 1M H CF UT1, 2 or 4	5.2	400 V, 2LN, PE, 50/60 Hz, 16 A
Evolution Plus	A II 1M HD CF UT1, 2 or 4	5.2	400 V, 2LN, PE, 50/60 Hz, 16 A
Add-on units	KE320 refrigeration unit	Standard with CF version	
	Cup warmer	Standard with under-counter CF version	
	Chocolate beverage dispenser		
Water connection	Supply line	Metal hose with union nut G3/8", l = 1.5 m	
	Water pressure	0.8 to 8.0 bar (80 bis 800 kPa)	
	Water hardness	Max. 7° dH, 13° fH	
	Chlorine content	Max. 100 mg/l	
	Ideal pH value	7	
Water outlet	Outlet hose	d = 16 mm, l = 2000 mm	
Versions	H	Hot water	
	D	Steam	
	M	Grinder	
	CF	Frothed milk / hot and cold milk	
	AS	Autosteam / Autofroth	
	KE320 UT	Under-counter refrigeration unit	

Evolution Plus performance characteristics

Characteristics	Evolution Plus	KE 320
Output per hour	Espresso	240 cups/hour
	Crème coffee	180 cups/hour
	Cappuccino	150 cups/hour
	White coffee	150 cups/hour
	Latte macchiato	150 cups/hour
	Hot milk	120 cups/hour
	Cold milk	150 cups/hour
	Hot water	25 l per hour
Electrical connection	Voltage, fuse protection	see above
	output, frequency	200V–240V, 1LN PE, 100 W, 10A
Dimensions	W × D × H (mm)	320 × 600 × 675**
		320 × 585 × 460

* Other electrical connection variants on request.

** Depending on the feet used.