

Franke Coffee Systems

Evolution:

The ultimate stage in coffeemaking competence.



FRANKE

COFFEE
SYSTEMS

The art of excellent coffeemaking

Evolution: Evolved to meet every challenge.



When it comes to above-average performance the modestly sized Evolution is certainly among the elite. The entry-level model alone has everything you need. With its perfected technology there is virtually no task it cannot handle. Its elegance is the delight of catering professionals, which is why the Evolution has such a huge fan base throughout the industry: in restaurants, bars, hotels, large canteens and even the vending sector. In short, it's a coffee machine with character – and it excels in one particular area:

The art of excellent coffeemaking



Evolution: Refined in every detail.



Operating panel

The focus is on easy operation. The large, clearly arranged product buttons are individually programmed and labelled. Whether in self-service operation with a maximum of 6 coffee products or in the operated version with up to 20 different coffee products: you're always in control.

Customer settings

The intelligent chip cards allow the user to set the key parameters himself in a matter of seconds, i.e. the amount of coffee to be ground and the amount of water and to correct any setting errors – without having to call out customer service. After installation the optimum setting values are stored on a chip card, from where they can be downloaded at any time.

Cleaning/hygiene

The integrated automatic rinsing and cleaning programme for the coffee and milk unit greatly facilitates the maintenance and care of the coffee machine, and ensures optimum hygiene and a consistently high coffee quality.

Dispenser area/operating area

Variable and sturdy. With the height of the coffee/milk dispenser adjusted steplessly from 80 to 150 mm, you can use all the popular sizes of cups and containers without problem. The optimised coffee supply system and the combined dispenser guarantee that the coffee is always at the ideal temperature and that cups are filled evenly when using the double-dispenser system. The dispenser is extremely easy to dismantle and can be cleaned in a dishwasher without any problem.



Add-ons:

The milk system – versatility made easy.

System-based milk preparation

With the Franke milk system, cappuccino, café latte, latte macchiato, and hot and cold milk are whisked into your coffee cup in an instant. The milk dispensing head is integrated directly into the coffee machine's dispenser system, which means you can dispense coffee and milk simultaneously using a single or double dispenser. The milk output sequence is programmable – either before, during or after the coffee. The compressor refrigerator stores the milk at a constant cool 5°C so that up to 6 litres of milk can be kept fresh for an extended period. The integrated electronic pump, which is electronically controlled and adapted to the programming of the coffee machine, ensures that the milk is dispensed in precise doses. The modular milk system is easy to operate and to clean – and is ideally integrated into the design of the Evolution.

For an immaculate appearance the automatic rinsing and cleaning programme makes sure the milk is processed under totally hygienic conditions at all times. The entire milk system is rinsed automatically either each time a product is dispensed or after a pre-programmable period of time. The dispenser head is easily accessible and, if the need arises, it can be removed for cleaning without the need to call out customer service.

Milk preparation at a glance

- Cold milk dispenser
- Adjustable milk temperature
- Consistent dosing
- Automatic cleaning and rinsing programme
- Level monitoring with visual indication on the machine's display
- Milk products halted when the milk container is empty
- Suitable for self-service and for connection to billing systems
- Cup monitoring (self-service)
- External "milk empty" indicator (self-service)
- Double cappuccinatore CF



Add-ons:

A la carte options, billing systems and add-on units.

Options for the Evolution

- Second grinder
- Special RAL colours
- Coffee grounds chute
- Self-service version
- Breakfast system
- Cappuccinatore CF1
- Cappuccinatore CF2
- Double cappuccinatore CF
- Franke milk system CF
- Trolley for mobile use

Billing systems

Billing unit for all commercially available systems: Attachment casing or add-on unit that perfectly integrates the required billing systems into the coffee station. Fitting of coin validator, coin changer and various debit-card systems.

- U-Key/Legic/EC Cash
- Waiter control system
- Token validator, coin changer
- Chip-card system

Add-on units

New: Chocolino Chocolate Dispenser: Hot chocolate at the touch of a button! Two product buttons are used to dispense portion sizes pre-programmable between 20 and 350 ml. Total output: 22 litres per hour. The rinsing button does all the cleaning – simply, at any time and in minutes.

Cup warmer for longer-lasting coffee enjoyment: constant, ideal cup temperature, 2 heated storage shelves, capacity: up to 80 cups.

Refrigeration unit for fresh milk: Stores milk at a constant 5°C, in conditions of perfect hygiene. Easy-to-clean refrigerated compartment and milk container. Refrigeration unit available as an add-on for equipment versions CF1 and CF2. Standard equipment for the Franke milk system. Option: lockable door.



Creative add-on variations: Tailored to your individual requirements.

Application example 1

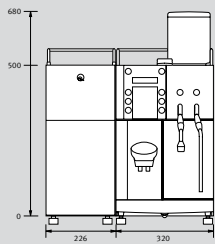

The all-rounder
The Evolution with refrigeration unit/milk system incl. hot-water and steam dispenser. A complete range of coffee and milk products from a single compact serving point.

Application example 3

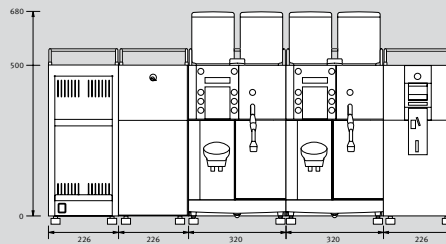

Perfect self-service
Cup warmer; the Evolution with milk system for all popular products; with hot-water dispenser. Connection of a standard commercial billing system in Evolution design.

Application example 2

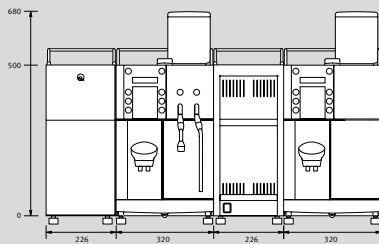

For high coffee outputs
The Evolution with milk system, hot-water and steam dispenser. Complementary Evolution for high coffee outputs. Both units with one grinder each. Cup warmer for ideal cup temperature.

Application example 4

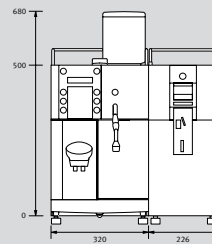

The Office solution
Evolution Office with one grinder; hot-water dispenser; connection of a standard commercial billing system.

Features of the Evolution entry-level and top-level models

Characteristics		Evolution entry-level model	Evolution top-level model
Output per hour	Coffee	120 cups/hour	180 cups/hour
	Espresso	180 cups/hour	240 cups/hour
	Cappuccino	120 cups/hour	150 cups/hour
	Latte macchiato	120 cups/hour	150 cups/hour
	Hot milk	120 cups/hour	120 cups/hour
	Cold milk	150 cups/hour	150 cups/hour
	Hot water	20 l per hour	25 l per hour
Electrical connection	Voltage, fuse protection	230 V, 1LN PE, 10 A	400 V, 2LN PE, 16 A
	Output, frequency	2.2 kW, 50/60 Hz	5.2 kW, 50/60 Hz
Dimensions	W × D × H (mm)	320 × 600 × 680	320 × 600 × 680

Evolution:

Smart technology and ultimate elegance.

In fact the Evolution is the darling of coffee aficionados and cool business minds alike. With its exclusive design this functional, compact machine is certainly an eye-catcher, and yet it's made to focus entirely on what's essential: producing an unmistakable coffee quality.



Evolution: Facts & Figures.

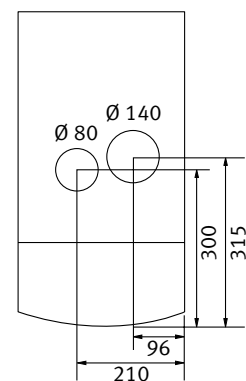
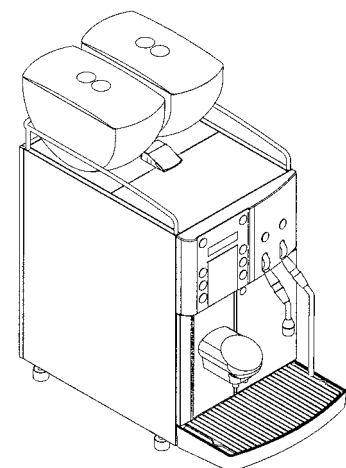
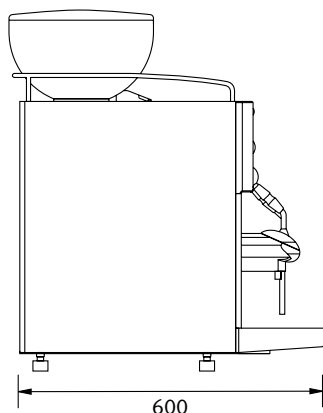
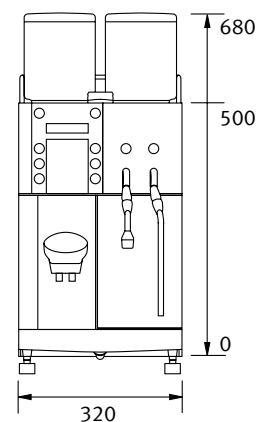

Standards

- Fully electronic control board with illuminated LCD; chip-card programming
- 5 (6) buttons for coffee/milk products; dual function using the Shift key; second programme selectable using a special function
- Up to 20 coffee products individually programmable
- Customised product labelling
- Low-noise precision grinder with direct grinding
- Repeat programme for each product
- Adjustable coffee dispenser from 80 to 150 mm
- Metal brewing unit with constant piston heater
- 1 or 2 high-grade stainless steel boilers for coffee, hot water/steam
- Automatic cleaning and rinsing programme
- Funnel for filling ground coffee manually
- Dry coffee grounds ejected into tray holding 50 portions, with electronic overflow safeguard
- Plastic coffee bean container, capacity 1.3 kg, removable
- Coffee bean level monitoring
- Internal counter functions for each product
- Prepared for connection to standard commercial dispensing and billing systems
- Stainless steel and plastic casing in anthracite or silver

	Types	Output in kW	Electrical connection
Entry-level model	E 1M H Office	2.2	230 V, 1LN PE, 50/60 Hz, 10 A
	E 1M H	2.2	230 V, 1LN PE, 50/60 Hz, 10 A
	E 1M HD	2.2	230 V, 1LN PE, 50/60 Hz, 10 A
	E 1M H CF1/CF2	2.2	230 V, 1LN PE, 50/60 Hz, 10 A
	E 1M HD CF1/CF2	2.2	230 V, 1LN PE, 50/60 Hz, 10 A
	E 1M H CF	2.2	230 V, 1LN PE, 50/60 Hz, 10 A
	E 1M HD CF	2.2	230 V, 1LN PE, 50/60 Hz, 10 A
Top-level model	EII 1M	2.2	230 V, 1LN PE, 50/60 Hz, 10 A
	EII 1M H	5.2	400 V, 2LN PE, 50/60 Hz, 16 A
	EII 1M HD	5.2	400 V, 2LN PE, 50/60 Hz, 16 A
	EII 1M H CF1/CF2	5.2	400 V, 2LN PE, 50/60 Hz, 16 A
	EII 1M HD CF1/CF2	5.2	400 V, 2LN PE, 50/60 Hz, 16 A
	EII 1M H CF	5.2	400 V, 2LN PE, 50/60 Hz, 16 A
	EII 1M HD CF	5.2	400 V, 2LN PE, 50/60 Hz, 16 A
	Other connection variants on request		
Add-on units	Refrigeration unit	70 W	230 V, 1LN PE, 50/60 Hz, 10 A
	Cup warmer	150 W	230 V, 1LN PE, 50/60 Hz, 10 A
Water connection	Supply line	Metal hose with union nut G3/8 _s , l = 1.5 m	
	Water pressure	0.8 to 8.0 bar (80 to 800 kPa)	
	Water hardness	Max. 7° dH, 13° fH	
	Chlorine content	Max. 100 mg/l	
	Ideal pH value	7	
Water outlet	Outlet hose	d = 16 mm, l = 2000 mm	
Versions	H	Hot water	
	D	Steam	
	M	Grinder	
	CF1	Foamed milk	
	CF2	Foamed milk/hot milk	
	CF	Foamed milk/hot and cold milk	